

JVC

SERVICE MANUAL

COLOUR TELEVISION

HV-34LPZ

HV-34LPZ_{/HK}

HV-34LPZ_{/A}

HV-34LPZ_{/EE}

BASIC CHASSIS
MF

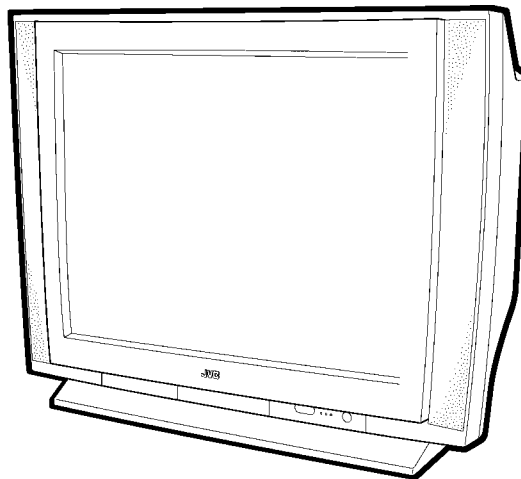
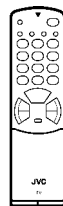

CONTENTS

■ SPECIFICATIONS	2	■ SPECIFIC SERVICE INSTRUCTIONS	8
■ SAFETY PRECAUTIONS	3	■ SERVICE ADJUSTMENTS	14
■ MAIN DIFFERENCE LIST	4	■ PARTS LIST	37
■ FEATURES	4	★ OPERATING INSTRUCTIONS	
■ FUNCTIONS	6	★ STANDARD CIRCUIT DIAGRAM	2-1

SPECIFICATIONS

Item	Content	
Dimensions (W × H × D)	89.8cm × 72.8cm × 57.9cm	
Mass	75.0kg	
TV RF System	B/G, I, D/K, K1, M	
Colour System	PAL / SECAM / NTSC 3.58 / NTSC 4.43	
Stereo System	A2 (B/G) / NICAM (B/G, I, D/K, K1)	
Teletext System	Fastext (UK system) * [* Without TEXT mode : HV-34LPZ/HK] WST(world standard system)	
Receiving Frequency	VL	46.25MHz ~ 168.25MHz
	VH	175.25MHz ~ 463.25MHz
	UHF CATV	471.25MHz ~ 863.25MHz
Intermediate Frequency	VIF	Mid (X~Z+2, S1~S10), Super (S11~S20) & Hyper (S21~S41) 38.0MHz
	SIF	32.5MHz(5.5MHz) / 32.0MHz(6.0MHz) / 3.15MHz(6.5MHz) / 33.5MHz (4.5MHz)
Colour Sub Carrier Frequency	PAL	4.43MHz
	SECAM	4.40625MHz / 4.25MHz
	NTSC	3.58MHz / 4.43MHz
Power Input	AC 110V~240V , 50/60Hz	
Power Consumption	Max 255W / Avg. 170W	
Aerial Input Term	75 Ω unbalanced, Coaxial	
Picture Tube	34"(87cm) measured diagonally	
High Voltage	32.0kV ^{+1.0kV} _{-1.5kV} (At zero beam current)	
Audio Power Output	20W + 20W	
Speaker	φ 12cm Round type × 2 / φ 3.5cm Round type × 2	
Input Terminal	Video	1Vp-p 75 Ω
	Audio (L/R)	500mVrms(-4dBs), High Impedance
	S / Video	Y : 1V(p-p) Positive (Negative sync provided) 75 Ω C : 0.286V(p-p) (burst signal), 75 Ω
Output Terminal	Component Cb/Cr	Y : 1V(p-p), 75 Ω Cb : B-Y 0.7V(p-p), 75 Ω / Cr : R-Y 0.7V(p-p), 75 Ω
	Video	1V(p-p) 75 Ω
	Audio (L/R)	500mVrms(-4dBs), Low Impedance
AV Compulink	Mono mini jack (φ 3.5mm)	
Headphone jack	Stereo mini jack (φ 3.5mm)	
Remote Control Unit	RM-C214 (AA/R06 / UM-3 , Dry cell battery × 2) : HV-34LPZ / HV-34LPZ/-A / HV-34LPZ/EE RM-C215 (AA/R06 / UM-3 , Dry cell battery × 2) : HV-34LPZ/HK	

Design & specifications are subject to change without notice.

SAFETY PRECAUTIONS

- The design of this product contains special hardware, many circuits and components specially for safety purposes. For continued protection, no changes should be made to the original design unless authorized in writing by the manufacturer. Replacement parts must be identical to those used in the original circuits. Service should be performed by qualified personnel only.
- Alterations of the design or circuitry of the products should not be made. Any design alterations or additions will void the manufacturer's warranty and will further relieve the manufacturer of responsibility for personal injury or property damage resulting therefrom.
- Many electrical and mechanical parts in the products have special safety-related characteristics. These characteristics are often not evident from visual inspection nor can the protection afforded by them necessarily be obtained by using replacement components rated for higher voltage, wattage, etc. Replacement parts which have these special safety characteristics are identified in the parts list of Service manual. **Electrical components having such features are identified by shading on the schematics and by (Δ) on the parts list in Service manual.** The use of a substitute replacement which does not have the same safety characteristics as the recommended replacement part shown in the parts list of Service manual may cause shock, fire, or other hazards.
- Don't short between the LIVE side ground and ISOLATED (NEUTRAL) side ground or EARTH side ground when repairing.**
Some model's power circuit is partly different in the GND. The difference of the GND is shown by the LIVE : (\perp) side GND, the ISOLATED(NEUTRAL) : (↯) side GND and EARTH : (\oplus) side GND. Don't short between the LIVE side GND and ISOLATED(NEUTRAL) side GND or EARTH side GND and never measure with a measuring apparatus (oscilloscope etc.) the LIVE side GND and ISOLATED(NEUTRAL) side GND or EARTH side GND at the same time.
If above note will not be kept, a fuse or any parts will be broken.
- If any repair has been made to the chassis, it is recommended that the B1 setting should be checked or adjusted (See ADJUSTMENT OF B1 POWER SUPPLY).
- The high voltage applied to the picture tube must conform with that specified in Service manual. Excessive high voltage can cause an increase in X-Ray emission, arcing and possible component damage, therefore operation under excessive high voltage conditions should be kept to a minimum, or should be prevented. If severe arcing occurs, remove the AC power immediately and determine the cause by visual inspection (incorrect installation, cracked or melted high voltage harness, poor soldering, etc.). To maintain the proper minimum level of soft X-Ray emission, components in the high voltage circuitry including the picture tube must be the exact replacements or alternatives approved by the manufacturer of the complete product.
- Do not check high voltage by drawing an arc. Use a high voltage meter or a high voltage probe with a VTVM. Discharge the picture tube before attempting meter connection, by connecting a clip lead to the ground frame and connecting the other end of the lead through a 10k Ω 2W resistor to the anode button.
- When service is required, observe the original lead dress. Extra precaution should be given to assure correct lead dress in the high voltage circuit area. Where a short circuit has occurred, those components that indicate evidence of overheating should be replaced. Always use the manufacturer's replacement components.

9. Isolation Check

(Safety for Electrical Shock Hazard)

After re-assembling the product, always perform an isolation check on the exposed metal parts of the cabinet (antenna terminals, video/audio input and output terminals, Control knobs, metal cabinet, screwheads, earphone jack, control shafts, etc.) to be sure the product is safe to operate without danger of electrical shock.

(1) Dielectric Strength Test

The isolation between the AC primary circuit and all metal parts exposed to the user, particularly any exposed metal part having a return path to the chassis should withstand a voltage of 3000V AC (r.m.s.) for a period of one second.

(. . . . Withstand a voltage of 1100V AC (r.m.s.) to an appliance rated up to 120V, and 3000V AC (r.m.s.) to an appliance rated 200V or more, for a period of one second.)

This method of test requires a test equipment not generally found in the service trade.

(2) Leakage Current Check

Plug the AC line cord directly into the AC outlet (do not use a line isolation transformer during this check.). Using a "Leakage Current Tester", measure the leakage current from each exposed metal part of the cabinet, particularly any exposed metal part having a return path to the chassis, to a known good earth ground (water pipe, etc.). Any leakage current must not exceed 0.5mA AC (r.m.s.).

However, in tropical area, this must not exceed 0.2mA AC (r.m.s.).

● Alternate Check Method

Plug the AC line cord directly into the AC outlet (do not use a line isolation transformer during this check.). Use an AC voltmeter having 1000 ohms per volt or more sensitivity in the following manner. Connect a 1500 Ω 10W resistor paralleled by a 0.15 μ F AC-type capacitor between an exposed metal part and a known good earth ground (water pipe, etc.). Measure the AC voltage across the resistor with the AC voltmeter. Move the resistor connection to each exposed metal part, particularly any exposed metal part having a return path to the chassis, and measure the AC voltage across the resistor. Now, reverse the plug in the AC outlet and repeat each measurement. Any voltage measured must not exceed 0.75V AC (r.m.s.). This corresponds to 0.5mA AC (r.m.s.).

However, in tropical area, this must not exceed 0.3V AC (r.m.s.). This corresponds to 0.2mA AC (r.m.s.).

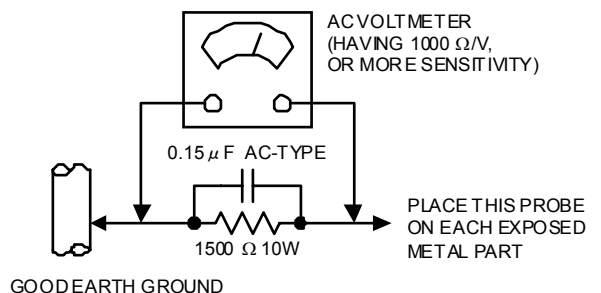

MAIN DIFFERENCE LIST

△	Model name		HV-34LPZ	HV-34LPZ/HK	HV-34LPZ/-A	HV-34LPZ/EE
	Part name					
	MICOM PWB		SMF0M801A-H2	SMF0M802A-H2	SMF0M803A-H2	SMF0M804A-H2
△	POWER CORD		QMP40D0-200J5	QMPN050-200-E2	QMPR010-200-E2	QMP40D0-200J5
△	FRONT CABI. ASSY		LC11231-001C-H	LC11231-010A-H	LC11231-001C-H	←
△	REAR COVER		LC10180-003A-HH	LC10180-005A-H	LC10180-003A-HH	←
△	RATING LABEL		LC20377-001B-H	LC20377-012B-H	LC20413-002B-H	LC20377-009B-H
△	INST BOOK		LCT1215-001A-H	LCT1217-001A-H	LCT1215-001A-H	LCT1218-001A-H
△	DIGEST MANUAL		×	×	LCT1216-001A-H	×
△	CONVERSION PLUG		×	×	QAM0055-001	×
	WARRANTY CARD		×	×	×	BT-54012-2
	REMOTE CONTROL UNIT		RM-C214-1C	RM-C215-1C	RM-C214-1C	←

FEATURES

- New chassis design enable use of an interactive on screen control.
- The TELETXT SYSTEM has a built-in FASTEXT (UK system), and WST (world standard system) system.
- Pure FLAT CRT reproduce fine textured.
- Digi Pure pro : Auto digi pure with motion picture compensation.
- Because this TV unit corresponds to multiplex broadcast, users can enjoy music programs and sporting events with live realism. In addition, BILINGUAL programs can be heard in their original language.
- Built-in ECO (ECONOMY, ECOLOGY) MODE.
In accordance with the brightness in a room, the brightness and/or contrast of the picture can be adjusted automatically to make the optimum picture which is easy on the eye.

SYSTEM BLOCK DIAGRAM

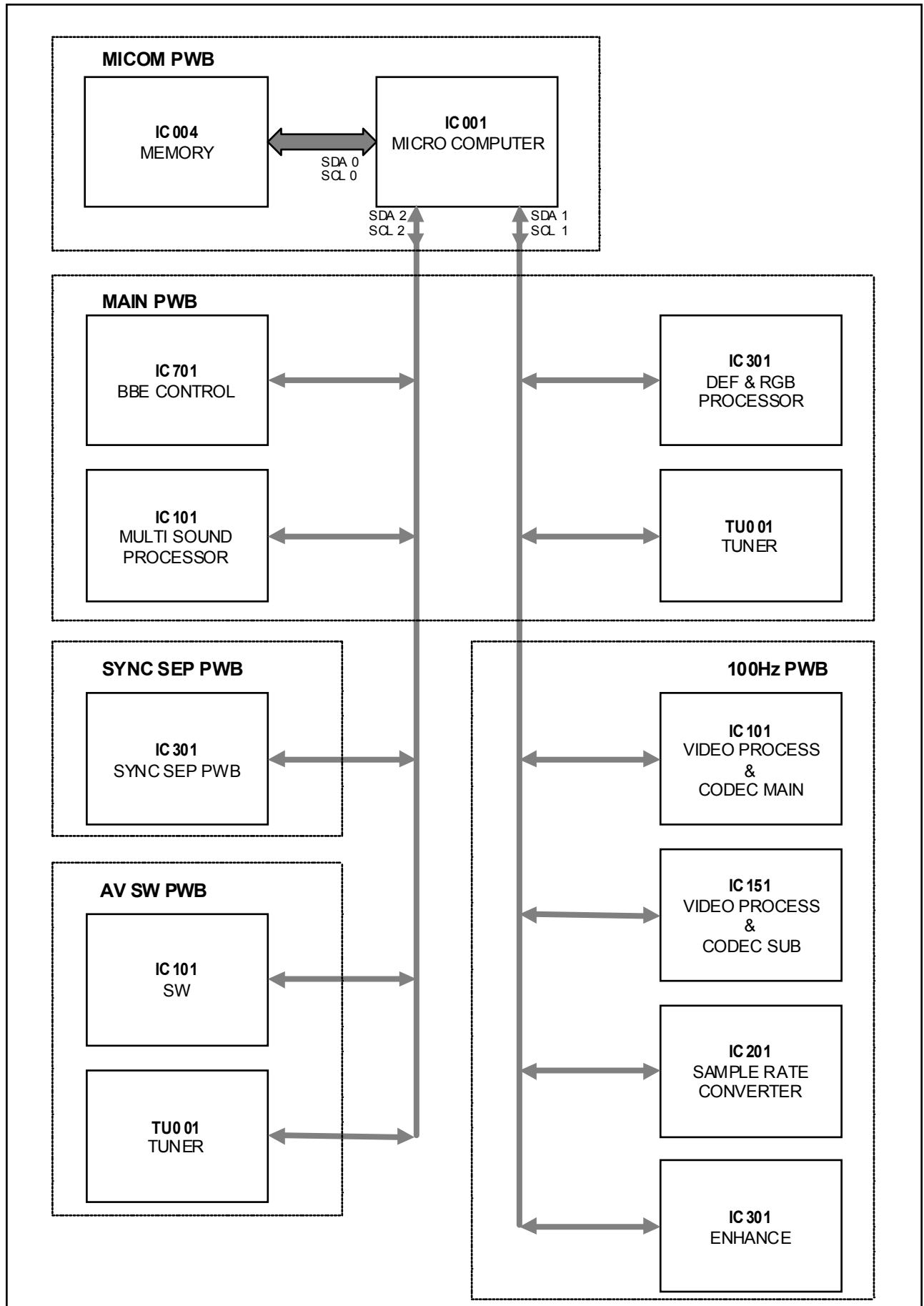

FUNCTIONS

■ Front Terminal & Control

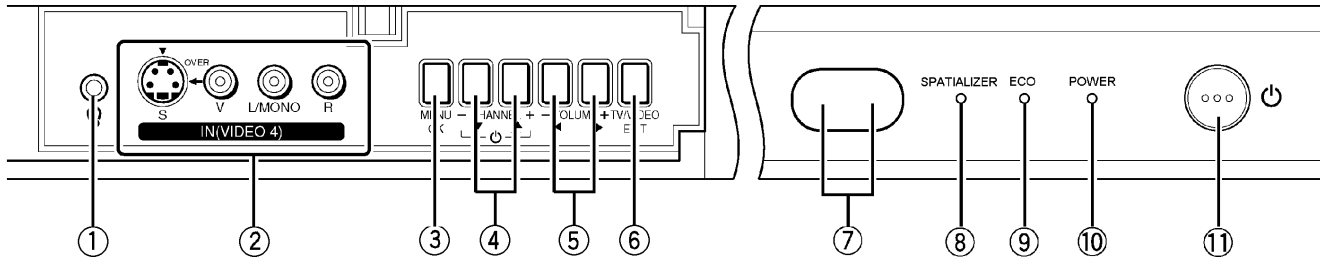

- ① HEADPHONE jack
- ② VIDEO-4 terminal (S-VIDEO / VIDEO / L/MONO / R)
- ③ MENU/OK Button
- ④ CHANNEL +/- (MENU UP/DOWN) Button
- ⑤ VOLUME +/- (MENU LEFT/RIGHT) Button
- ⑥ TV/VIDEO / EXIT Button (Input select)
- ⑦ SENSOR (Remote Control & ECO)
- ⑧ SPATIALIZER LAMP
- ⑨ ECO LAMP
- ⑩ POWER LAMP
- ⑪ POWER SW Button (MAINPOWER on and off)

■ Rear Terminal

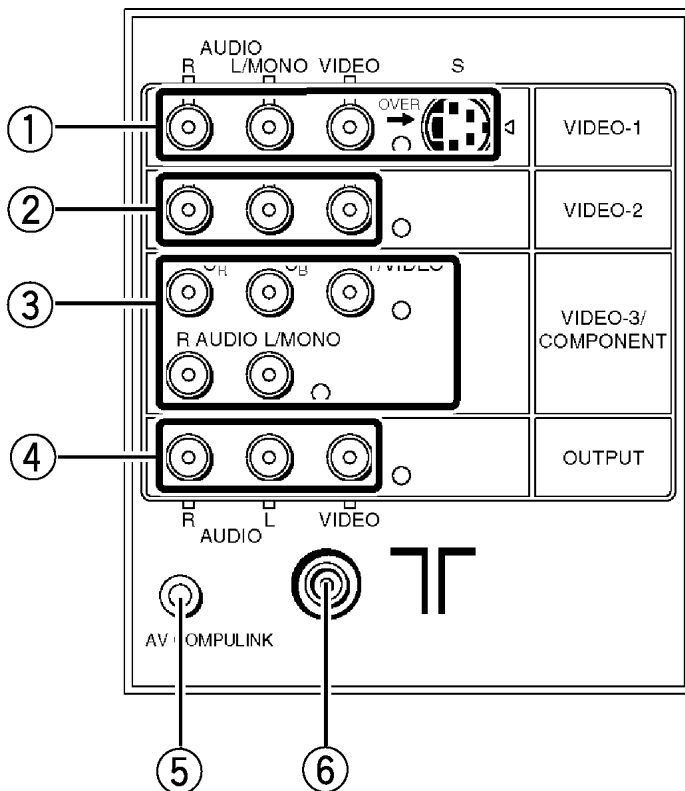

- ① VIDEO-1 (INPUT) terminal (S, V, L, R)
- ② VIDEO-2 (INPUT) terminal (V, L, R)
- ③ VIDEO-3 (INPUT) terminal (V/Y, Cb, Cr, L, R) / COMPONENT
- ④ OUTPUT (AUDIO/VIDEO) terminal (V, L, R)
- ⑤ AV COMPULINK terminal
- ⑥ AERIAL socket

■ Remote Control Unit

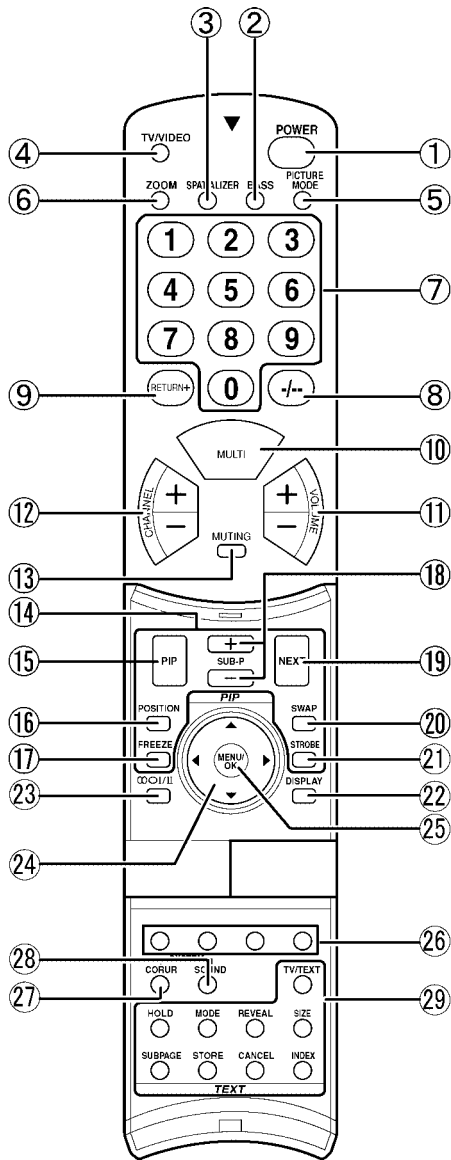

- ① POWER Key
(SUB POWER on and off)
- ② BASS Key
(SUPER BASS function on or off)
- ③ SPATIALIZER Key
(Choose a mode LIVE → MONO → OFF)
- ④ TV/VIDEO Key
- ⑤ PICTURE MODE Key
(Choose a mode BRIGHT → STANDARD → SOFT)
- ⑥ ZOOM Key
(Choose a mode REGULAR → ZOOM → 16:9)
- ⑦ CHANNEL Key
- ⑧ -/-- Key
- ⑨ RETURN + Key
- ⑩ MULTI Key
- ⑪ VOLUME +/- Key
- ⑫ CHANNEL +/- Key
- ⑬ MUTING Key
- ⑭ PIP MODE
- ⑮ PIP Key
- ⑯ POSITION Key
- ⑰ FREEZE Key
[View the MAIN picture's frozen image as the SUB-PICTURE.]
- ⑱ SUB P (PIP)+&- Key
- ⑲ NEXT Key
- ⑳ SWAP Key
- ㉑ STROBE Key
[View the MAIN-picture as 15 consecutive Still image.]
- ㉒ DISPLAY Key
- ㉓ STEREO ∞ I / II Key
[∞ : Stereo / \circ : Mono
I : Bilingual (sub I)
II : Bilingual (sub II)]
- ㉔ FUNCTION Key(▲/▼& ◀/▶)
- ㉕ MENU/OK Key
- ㉖ COLOUR Key
(Choose the appropriate colour system.)
- ㉗ COLOUR SYSTEM Key
(Choose the appropriate colour system.)
- ㉘ SOUND SYSTEM Key
(Choose the appropriate sound system.)
- ㉙ TELETEXT Key
(Without HV-34LPZ/HK)

SPECIFIC SERVICE INSTRUCTIONS

DISASSEMBLY PROCEDURE

REMOVING THE REAR COVER

1. Unplug the power cord.
2. Remove the 18 screws marked (A) as shown in the Fig. 1.
3. Withdraw the rear cover toward you.

REMOVING THE AV TERMINAL BOARD

- After removing the rear cover.
1. Remove the 5 screws marked (B) as shown in the Fig. 1.
 2. Withdraw the AV terminal board toward you.

REMOVING THE CHASSIS

- After removing the rear cover.
1. Slightly raise the both sides of the chassis by hand and remove the 2 claws under the both sides of the chassis from the front cabinet.
 2. Withdraw the chassis backward.
(If necessary, take off the wire clamp, connectors etc.)

REMOVING THE DOME SPEAKER BOX / SPEAKER

- After removing the rear cover.
1. As shown in Fig. 1, remove the 2 screws marked (C), then remove the dome speaker box.
 2. Remove the 5 screws marked (D) as shown in the Fig.2, then remove the dome box.
 3. Remove the 4 screws marked (E) as shown in the Fig.2, then remove the speaker.
 4. Follow the same steps when removing the other hand dome speaker box.

NOTE : When removing the screws marked (C) of the dome speaker box, remove the lower side screw first, and then remove the upper one.

REMOVING THE TWEETER SPEAKER

- After removing the rear cover.
1. As shown in Fig. 1, remove the 2 screws marked (F), then pull out the tweeter speaker to remove it.

CHECKING THE PW BOARD

To check the back side of the PW Board.

- 1) Pull out the chassis. (Refer to REMOVING THE CHASSIS).
- 2) Erect the chassis vertically so that you can easily check the back side of the PW Board.

[CAUTION]

- When erecting the chassis, be careful so that there will be no contacting with other PW Board.
- Before turning on power, make sure that the wire connector is properly connected.
- When conducting a check with power supplied, be sure to confirm that the CRT EARTH WIRE (BRAIDED ASS'Y) is connected to the CRT SOCKET PW board.

WIRE CLAMPING AND CABLE TYING

1. Be sure to clamp the wire.
2. Never remove the cable tie used for tying the wires together.
Should it be inadvertently removed, be sure to tie the wires with a new cable tie.

- **DOME SPEAKER BOX**

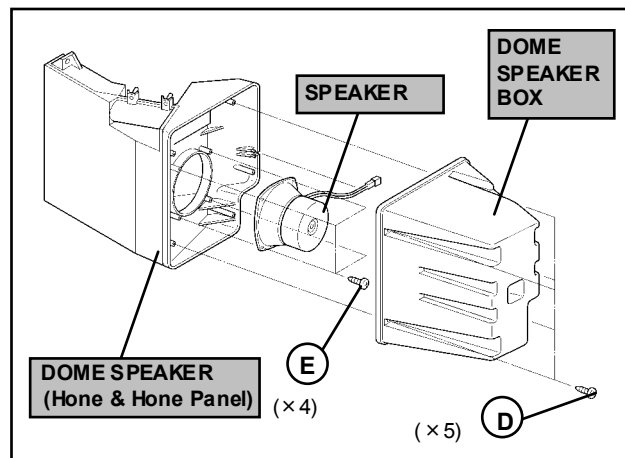

Fig. 2

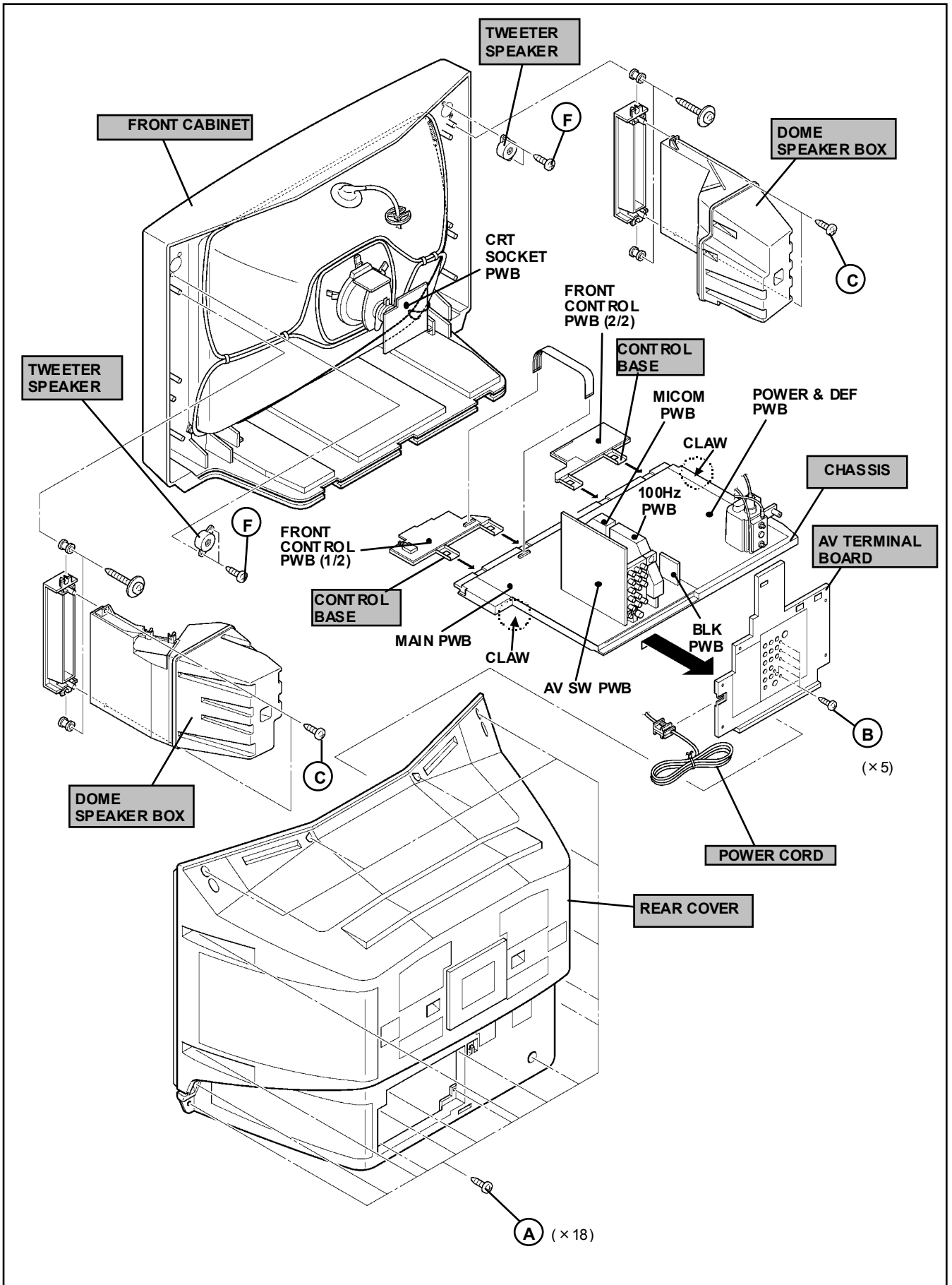

Fig. 1

REMOVING THE CRT

- * Replacement of the CRT should be performed by 2 or more persons.
- After removing the cover, chassis etc.,
- 1. Putting the CRT change table on soft cloth, the CRT change table should also be covered with such soft cloth (shown in Fig.3).
- 2. While keeping the surface of CRT down, mount the TV set on the CRT change table balanced will as shown in Fig.4.
- 3. Remove 4 screws marked by arrows with a box type screw driver as shown in Fig.4.
- Since the cabinet will drop when screws have been removed, be sure to support the cabinet with hands.
- 4. After 4 screws have been removed, put the cabinet slowly on cloth (At this time, be carefully so as not to damage the front surface of the cabinet) shown in Fig.5.
- The CRT should be assembled according to the opposite sequence of its dismantling steps.
- * The CRT change table should preferably be smaller than the CRT surface, and its height be about 35cm. (Fig.3)
- * About CRT Spacer (Fig.4)
An appropriate CRT spacer should be used in the corresponding CRT in accordance with the type of the CRT.
When a CRT is replaced, special attention should be paid to this matter.

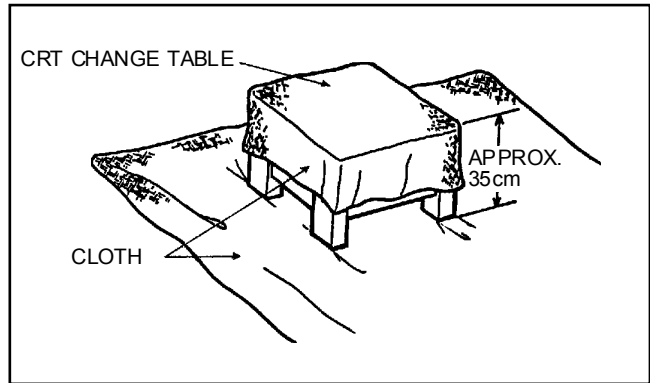

Fig. 3

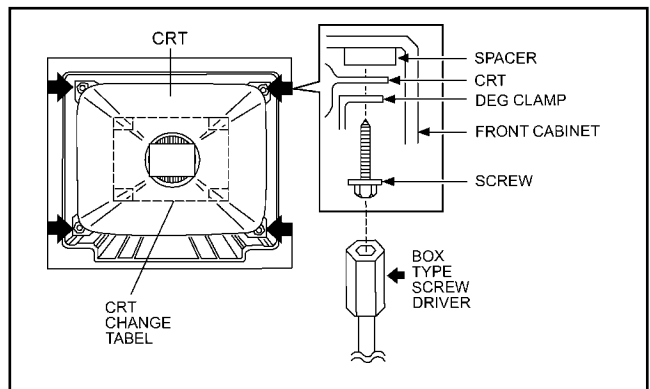

Fig. 4

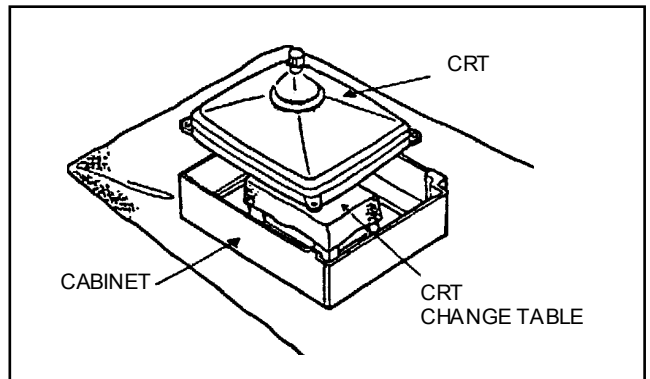

Fig. 5

COATING OF SILICON GREASE FOR ELECTRICAL INSULATION ON THE CRT ANODE CAP SECTION.

- Subsequent to replacement of the CRT and HV transformer or repair of the anode cap, etc. by dismantling them, be sure to coat silicon grease for electrical insulation as shown in Fig.6. Wipe around the anode button with clean and dry cloth. (Fig.6) Coat silicon grease on the section around the anode button. At this time, take care so that any silicon greases dose not stick to the anode button. (Fig.7)

★ Silicon grease product No. KS - 650N

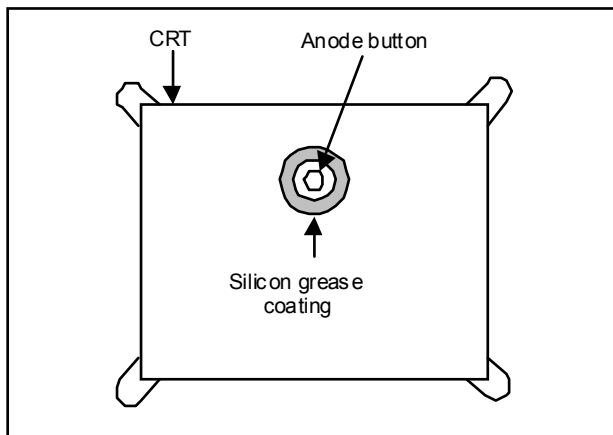

Fig. 6

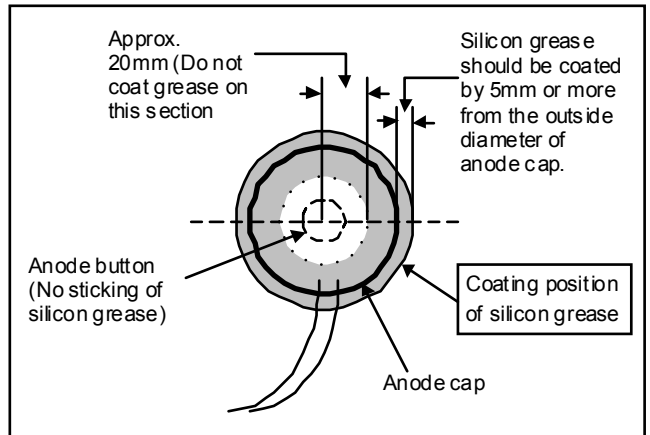

Fig. 7

REPLACEMENT OF MEMORY ICs

1. Memory ICs

This TV use memory ICs. In the memory ICs, there are memorized data for correctly operating the video and deflection circuits. When replacing memory ICs, be sure to use ICs written with the initial values of data.

2. Procedure for replacing memory ICs

- (1) **Power off**
Switch the power off and unplug the power cord from the wall outlet.
- (2) **Replace ICs.**
Be sure to use memory ICs written with the initial data values.
- (3) **Power on**
Plug the power cord into the wall outlet and switch the power on.

SERVICE MENU	
1. IF	2. V/C
3. AUDIO	4. DEF
5. VSM PRESET	6. STATUS
7. PIP	8. WB PRESET
9. SHIPPING(OFF)	0. BUS FREE
1-0 : SELECT	DISP : EXIT

Fig.1

(4) Check and set SYSTEM CONSTANT SET :

* It must not adjust without signal.

- 1) Press the DISPLAY key and the PICTURE TUBE key of the REMOTE CONTROL UNIT simultaneously.
- 2) The SERVICE MENU screen of Fig. 1 will be displayed.
- 3) While the SERVICE MENU is displayed, press the DISPLAY key and PICTURE TUBE key simultaneously, and the SYSTEM CONSTANT SET screen of Fig. 2 will be displayed.
- 4) Check the setting values of the SYSTEM CONSTANT SET of Table 1. If the value is different, select the setting item with the FUNCTION UP/DOWN key, and set the correct value with the FUNCTION +/- key.
- 5) Press the MENU(OK) key to memorize the setting value.
- 6) Press the INFORMATION key, and return to the normal screen.

SYSTEM CONSTANT SET	
1. TEXT	**
-/+  : STORE DISP : EXIT	

Fig.2

2. BLUE BACK MENU	**
3. E.M.C	**
4. WHITE BACK	**
5. COLOUR AUTO	**
6. PICTURE TILT	**

- (5) **Setting of receive channels**
Set the receive channel.
For setting, refer to the OPERATING INSTRUCTIONS.
- (6) **Setting of SERVICE MENU**
Verify the setting items of the **SERVICE MENU** of Table 2, and reset where necessary.
For setting, refer to the SERVICE ADJUSTMENTS.
- (7) **User settings**
Check the user setting values of Table 3, and if setting value is different, set the correct value.
For setting, refer to the OPERATING INSTRUCTIONS.

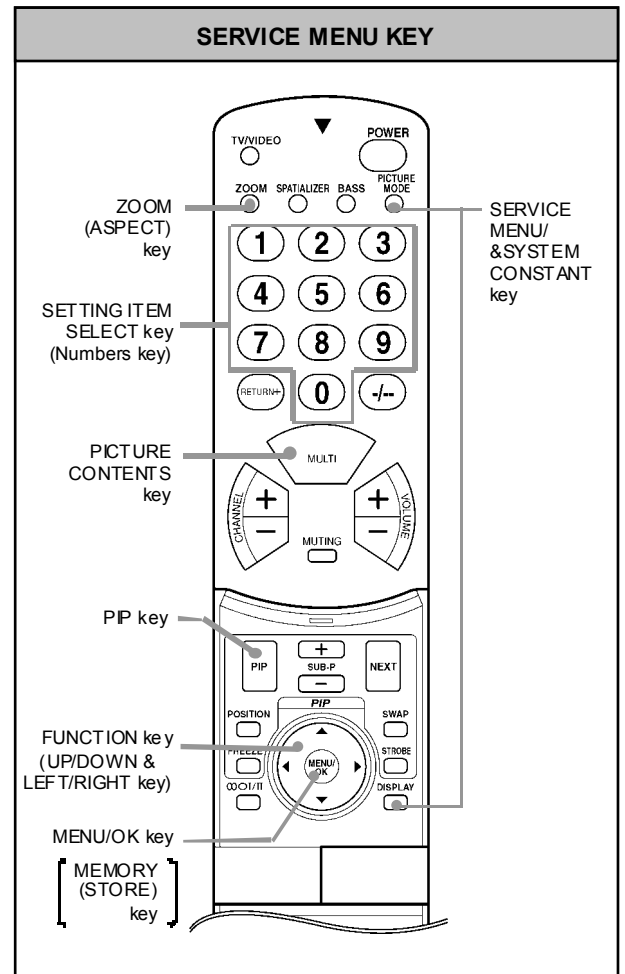

SETTING VALUES OF SYSTEM CONSTANT SET (TABLE 1)

MODEL No. Setting item	HV-34LPZ	HV-34LPZ/-A	HV-34LPZ/HK	HV-34LPZ/EE
1. TEXT	YES	←	NO	YES
2. BLUE BACK MUTE	NO	YES	NO	←
3. E. M. C	NO	←	←	←
4. WHITE BACK	NO	←	←	←
5. COLOUR AUTO	NO	YES	NO	←
6. PICTURE TILT	YES	←	←	←

SERVICE MENU SETTING ITEMS (TABLE 2)

Setting item	Setting value	Setting item	Setting value
1. IF	1. VCO 2. ATT ON / OFF	5. VSM PRESET BRIGHT STANDARD SOFT	1. CONT. 2. BRIGHT 3. SHARP 4. COLOUR 5. TINT
2. V / C	1. RGB BLK 2. WDR R 3. WDR G 4. WDR B 5. BRIGHT 6. CONTRAST 7. COLOUR 8. TINT 9. SHARP 10. VCO ADJ. 11. VID ADJ. 12. SYNC SLICE		
3. AUDIO (Do not adjust)	1. ERR LIMIT 2. A2 ID THR 3. SYSTEM	6. STATUS (Do not adjust)	1. SOFT 2. TELETEXT 3. ASPECT
4. DEF.	1. V-SHIFT 2. V-SIZE 3. H-CENT 4. H-SIZE 5. TRAPEZ 6. EW-PIN 7. COR-PIN 8. COR-UP 9. COR-LO 10. ANGLE 11. BOW 12. V-S.CR 13. V.LIN 14. V.BLK-UP	7. PIP	1. PIP VCO ADJ 2. PIP VIDAGC 3. PIP SYNC SLICE
		8. WB PRESET	1. WDR R 2. WDR G 3. WDR B

USER SETTING VALUES (TABLE 3)

Setting item	Setting value	Setting item	Setting value
MAIN POWER SW	OFF	SUB POWER	ON
SHIPPING CHANNEL	PR1	DISPLAY	INDICATED
PRESET CHANNEL	See ; OPERATING INSTRUCTIONS.	VOLUME LEVEL	10
PICTURE SETTING		INSTALL	
PICTURE MODE	BRIGHT	LANGUAGE	ENGLISH
WHITE MODE	MID	EDIT	<ul style="list-style-type: none"> ● PRESET CHANNEL ONLY ● OTHER : NON (SPACE)
ECO MODE	OFF		
PICTURE FEATURES		FEATURES	
DIGITAL VNR	AUTO	SLEEP TIMER	OFF
DIGIPURE PRO	AUTO	BLUE BACK	ON
COLOUR SYSTEM	<ul style="list-style-type: none"> ● TV : Depends on PR/CH ● EXT : AUTO 	AUTO SHUT OFF	OFF
ZOOM	REGULAR	VIDEO-3 SETTING	COMPONENT
PICTURE TILT	CENTER	CHILD LOCK	OFF (for all the channels)
		CHANNEL GUARD	ALL CH : OFF
SOUND			
BASS	CENTER	BEE	ON
TREBLE	CENTER	SUPERBASS	ON
BALANCE	CENTER	AI VOLUME	ON
SPATIALIZER	OFF		

SERVICE ADJUSTMENTS

BEFORE STARTING SERVICE ADJUSTMENT

1. There are 2 ways of adjusting this TV: One is with the REMOTE CONTROL UNIT and the other is the conventional method using adjustment parts and components.
2. The setting (adjustment) using the REMOTE CONTROL UNIT is made on the basis of the initial setting values. The setting values which adjust the screen to the optimum condition can be different from the initial setting values.
3. Make sure that connection is correctly made to AC power source.
4. Turn on the power of the TV and measuring instrument for warming up for at least 30 minutes before starting adjustment.
5. If the receive or input signal is not specified, use the most appropriate signal for adjustment.
6. **Never touch parts** (such as variable resistors, transformers and condensers) **not shown in the adjustment items of this service adjustment.**
7. Preparation for adjustment (presetting):
Unless otherwise specified in the adjustment items, preset the following functions with the REMOTE CONTROL UNIT:
 - Setting position

PICTURE MODE (VSM)	STANDARD
SLEEP TIMER	OFF
BALANCE	CENTER
ECO	OFF
ZOOM	REGULAR

MEASURING INSTRUMENT AND FIXTURES

1. DC voltmeter (or digital voltmeter)
2. Oscilloscope
3. Signal generator (Pattern generator) [PAL / SECAM / NTSC]
4. Remote control unit

ADJUSTMENT ITEMS

- Checking items.
- Adjustment of FOCUS/SCREEN.
- VSM preset setting.
- VIDEO / CHROMA circuit adjustment.
- DEFLECTION circuit adjustment.
- AUDIO circuit adjustment. **(Do not adjust)**

ADJUSTMENT LOCATIONS

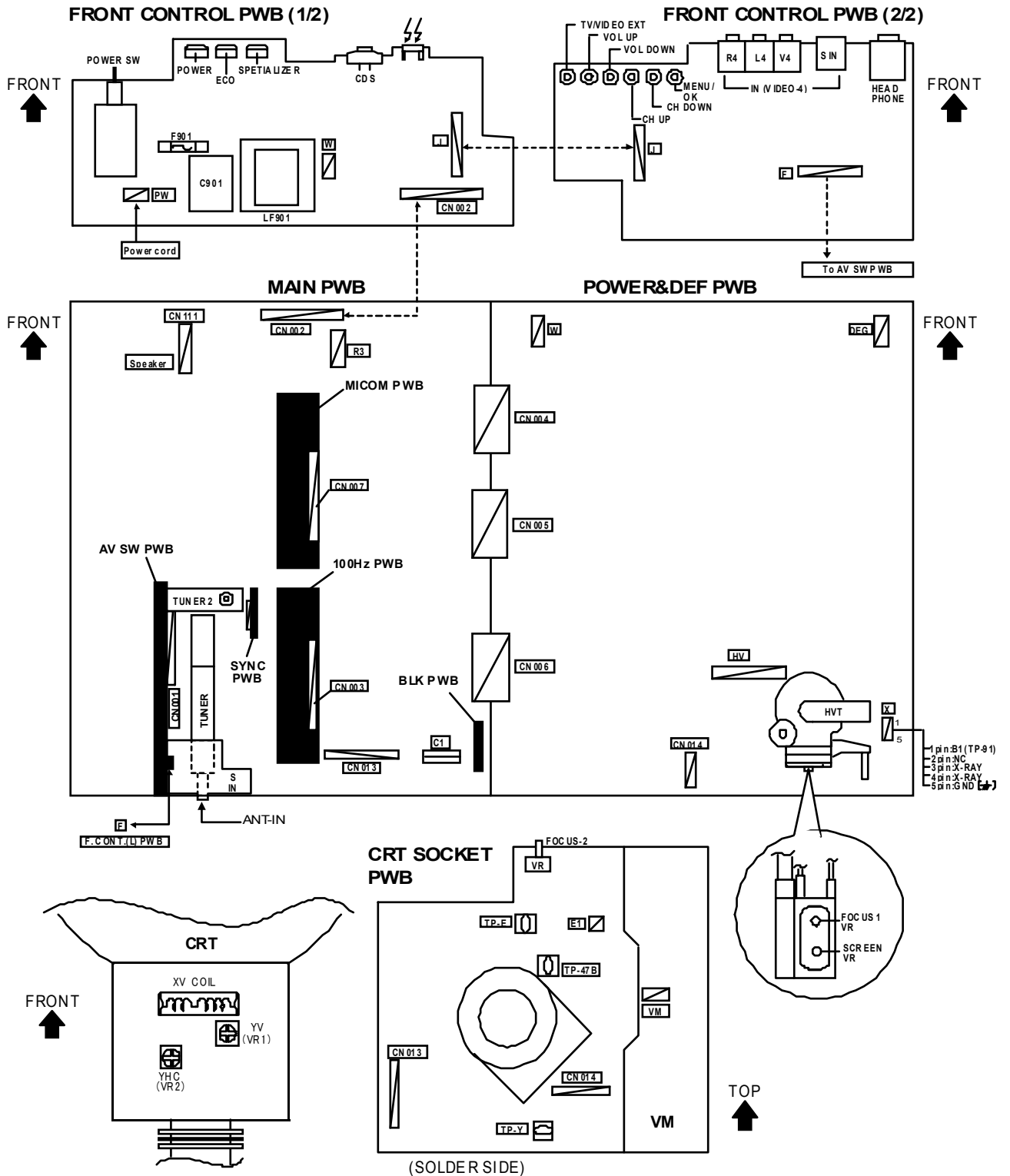

BASIC OPERATION SERVICE MENU

1. TOOL OF SERVICE MENU OPERATION

Operate the SERVICE MENU with the REMOTE CONTROL UNIT.

2. SERVICE MENU ITEMS

With the SERVICE MENU, various settings (adjustments) can be made, and they are broadly classified in the following items of settings (adjustments):

- (1) **1. IF** This mode adjusts the setting values of the IF circuit.
- (2) **2.V/C** This mode adjusts the setting values of the VIDEO / CHROMA circuit.
- (3) **3.AUDIO** This mode adjusts the setting values of the SOUND circuit. (Do not adjust)
- (4) **4.DEF** This mode adjusts the setting values of the DEFLECTION circuit for each aspect mode given below.

ZOOM (ASPECT)	V. FREQ.
REGULAR	100HzI / 60HzP
ZOOM	↑
16 : 9	↑

- (5) **5.VSM PRESET** This mode adjusts the initial setting values of Bright, Standard & soft.
(VSM : Video Status Memory)
- (6) **6.STATUS** It is no requirement to adjustment.
- (7) **7.PIP** This mode adjusts the setting values of the PIP circuit. (PIP : Picture In Picture)
- (8) **8.WB PRESET** This mode adjusts the setting values of the WHITE BALANCE.
- (9) **9.SHIPPING(OFF)** This mode adjusts the setting values of the channel presettings.
If you turn the SHIPPING position set ON.
This setting becomes channel presetting automatically.
Also you turn the TV power off, this setting become OFF position automatically.
- (10) **0.BUS FREE** It is not requirement to adjustment.

3. BASIC OPERATION OF SERVICE MENU

(1) How to enter SERVICE MENU

Press the PICTURE MODE key and the DISPLAY key of the REMOTE CONTROL UNIT simultaneously, and the SERVICE MENU screen of Fig. 1 will be displayed.

(2) Selection of SUB MENU SCREEN

Press one of keys 1~0 of the REMOTE CONTROL UNIT and select the SERVICE MENU SCREEN (See Fig. 3), from the SERVICE MENU.

SERVICE MENU → SUB MENU

- 1. IF
- 2. V / C
- 3. AUDIO (Do not adj.)
- 4. DEF.
- 5. VSM PRESET
- 6. STATUS (Do not adj.)
- 7. PIP
- 8. WB PRESET
- 9. SHIPPING (OFF)
- 0. BUS FREE

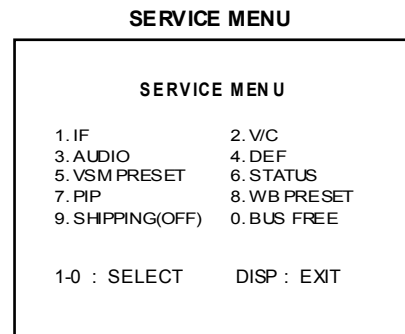
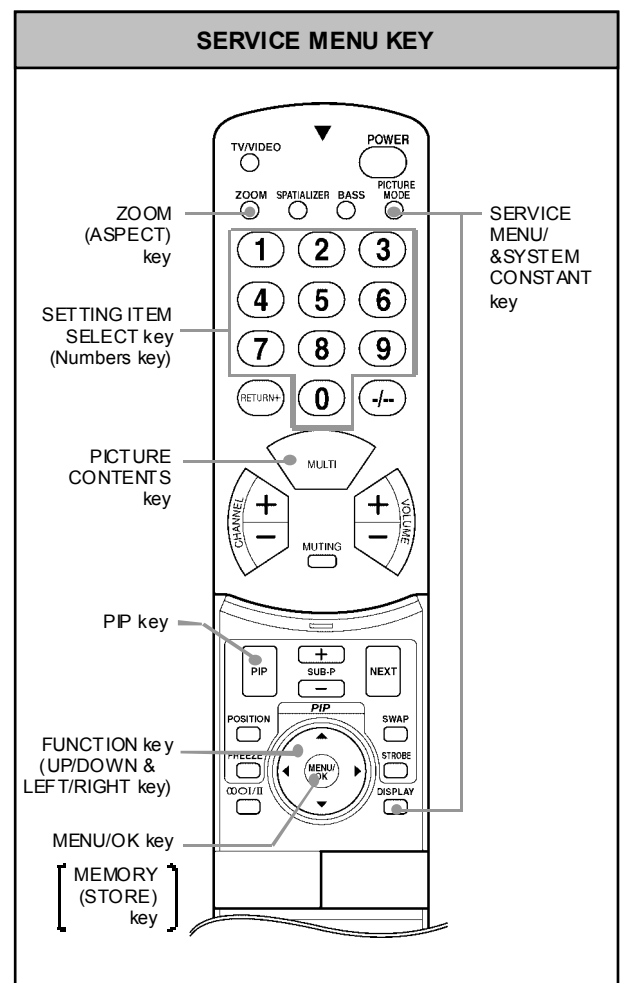
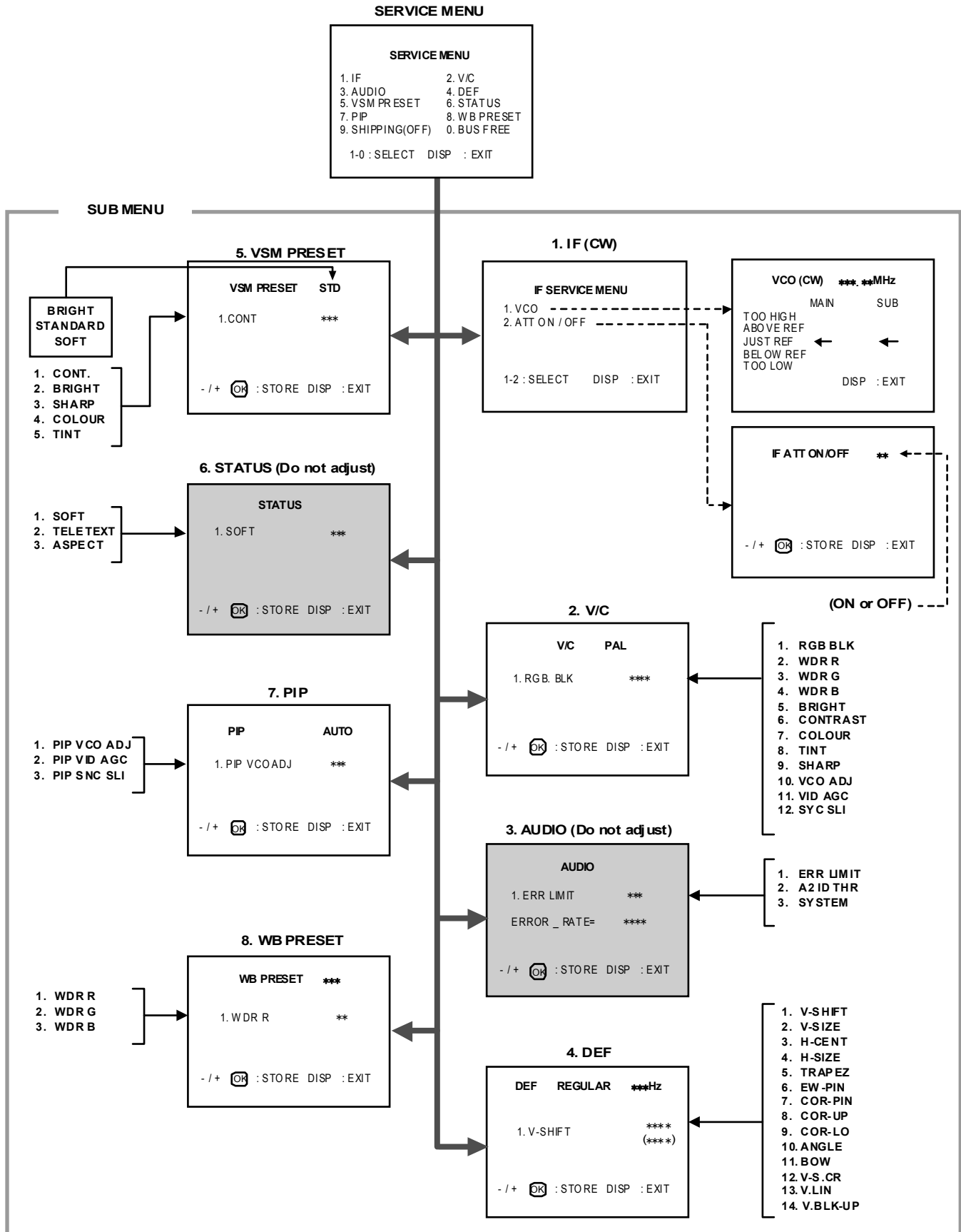

Fig.1



SERVICE MENU SCREEN



2. V/C

V/C PAL

1. RGB. BLK ****

- / + : STORE DISP : EXIT

- 1. RGB BLK
- 2. WDR R
- 3. WDR G
- 4. WDR B
- 5. BRIGHT
- 6. CONTRAST
- 7. COLOUR
- 8. TINT
- 9. SHARP
- 10. VCO ADJ
- 11. VID AGC
- 12. SYC SLI

3. AUDIO (Do not adjust)

AUDIO

1. ERR LIMIT ***

ERROR_RATE= ****

- / + : STORE DISP : EXIT

- 1. ERR LIMIT
- 2. A2 ID THR
- 3. SYSTEM

8. WB PRESET

WB PRESET ***

1. WDR R **

- / + : STORE DISP : EXIT

- 1. WDR R
- 2. WDR G
- 3. WDR B

DEF REGULAR ***Hz

1. V-SHIFT ****

 (****)

- / + : STORE DISP : EXIT

Fig. 3

(3) Method of Setting

● Method of Setting **1.IF**

[VCO] * It must not adjust without signal

- ① 1 Key Select 1.IF.
- ② 1 Key Select 1. VCO (CW)
Check the arrow position between the ABOVE REF. and BELOW REF.
- ③ 2 Key Select 2.ATT ON/OFF (Strong Electric Field : ON / Generally Electric Field : OFF)
- ④ DISPLAY(DISP) Key Return to the SERVICE MENU screen.

● Method of setting **2.V/C, 4.DEF, 5.VSM PRESET, 7.PIP and 8.WB PRESET.**

- ① 2, 4, 5, 7 & 8 Key Select one from **2. V/C, 4. DEF, 5. VSM PRESET, 7.PIP & 8.WB PRESET.**
- ② FUNCTION UP/DOWN Key Select setting items.
- ③ FUNCTION +/- Set (adjust) the setting values of the setting items.
- ④ MENU (OK) Key Memorize the setting value.
(Before storing the setting values in memory, do not press the CH, TV, POWER ON / OFF key - if you do, the values will not be stored in memory.)
- ⑤ DISPLAY (DISP) Key Return to the **SERVICE MENU** screen.

● **3. AUDIO, 6. STATUS, 9. SHIPPING(OFF) & 0. BUS FREE.**

It is not requirement to adjustment.

(4) Release of SERVICE MENU

- 1) After completing the setting, return to the SERVICE MENU, then again press the DISPLAY (DISP) key.

ADJUSTMENT

CHECKING ITEM

Item	Measuring instrument	Test point	Adjustment part	Description
Check of B1 Power Supply	Signal Generator DC voltmeter Remote Control unit	TP-91(B1) TP-E(↗) [X connector on POWER DEF PWB]	1. RGB BLK	<ol style="list-style-type: none"> 1. Receive any broadcast. 2. Press the ZOOM key and select the FULL mode. 3. Select 2. V/C from the SERVICE MENU. 4. Select 1. RGB BLK with function UP / DOWN key. 5. Press the function (▶) key to find the cut off screen (Black screen). 6. Connect a DC voltmeter to TP-91(B1) and TP-E(↗). 7. Make sure that the voltage is DC139.9 ±2.0V. 8. Press the function (◀) key to return to service menu.
Check of High Voltage	Signal Generator DC voltmeter Remote Control unit	CRT anode Chassis GND	1. RGB BLK	<ol style="list-style-type: none"> 1. Receive any broadcast. 2. Press the ZOOM key and select the FULL mode. 3. Select 2. V/C from the SERVICE MENU. 4. Select 1. RGB BLK with function UP / DOWN key. 5. Press the function (▶) key to find the cut off screen (Black screen). 6. Connect a DC voltmeter to CRT ANODE and chassis GND. 7. Make sure that the voltage is DC 32.0kV ±1.5kV. 8. Press the function (◀) key to return to service menu. <p>* Remove the probe before removing the earth clip.</p>
Check of VCO	Remote control unit		<ol style="list-style-type: none"> 1. VCO 2. ATT ON/OFF 	<ul style="list-style-type: none"> ● Under normal conditions, no adjustment is required. ● Confirmation adjustment. <hr/> <ol style="list-style-type: none"> 1. Select 1.IF from the SERVICE MENU. 2. Then select 1.VCO from the IF SERVICE MENU. 3. Receive any broadcast. 4. Check the MAIN arrow (←) position between the ABOVE REF. and BELOW REF. 5. Press the MENU (OK) key and receive any broadcast with PIP Button. 6. Check the SUB arrow (←) position between the ABOVE REF. and BELOW REF. <p>* The arrow (←) position means AFC voltage level. * 2. ATT ON/OFF : Generally Electric Field : OFF : Strong Electric Field : ON * Change the MAIN and SUB by MENU/OK key .</p>

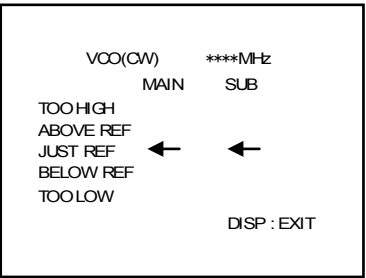
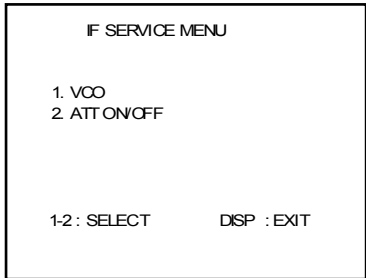

ADJUSTMENT OF FOCUS & SCREEN

Item	Measuring instrument	Test point	Adjustment part	Description
<p>Adjustment of FOCUS</p>	<p>Signal generator</p>		<p>FOCUS 1 VR(In HVT) FOCUS 2 VR (IN CRT SOCKET PWB)</p>	<ol style="list-style-type: none"> 1. Receive a cross-hatch signal. 2. Press the ZOOM key and select the regular mode. 3. By turning the FOCUS 1 VR, adjust the to make the vertical lines as fine and sharp as possible. 4. By turning the FOCUS 1 VR, adjust the picture so that the 5th vertical line from left side of the cross-hatch picture becomes thinnest. 5. By turning the FOCUS 2 VR(In CRT SOCKET PWB), adjust the 3rd horizontal line from the upper side may become uniform at the line center and its periphery. 6. Carry out adjustment by repeating the steps 3, 4 and 5 about. 7. Make sure that the screen is darkened, the lines remain in good focus.
<p>Adjustment of SCREEN VR</p>	<p>Signal generator</p>		<p>SCREEN VR (In HVT)</p>	<ol style="list-style-type: none"> 1. Receive a whole black signal . 2. Press the ZOOM key and select the regular mode. 3. Select 2. V/C from the SERVICE MENU. 4. Rotate the SCREEN VR (In HVT) clockwise(from 1→0→1) from the full counterclockwise slowly and stop it at the point where "CLOW" status (marked in Fig.) changes from 1 to 0 (which is indicated at the 3rd column from the right). <p>* "CLOW" : control loopout of window.</p>

VSM PRESET SETTING

Item	Measuring instrument	Test point	Adjustment part	Description
Setting of VSM PRESET	Remote control unit		1. CONT. 2. BRIGHT 3. SHARP 4. COLOUR 5. TINT	1. Select 5.VSM PRESET from the SERVICE MENU. 2. Select STD with the PICTURE MODE key of the remote control unit. 3. Adjust the function UP/DOWN and LEFT/RIGHT key to bring the set values of 1.CONT ~ 5. TINT to the values shown in the table. 4. Press the MENU/OK key and memorize the set value. 5. Respectively select the VSM PRESET mode for REGULAR and BRIGHT, and make similar adjustment as in 3 above. 6. Press the MENU/OK key and memorize the set value. * Refer to OPERATING INSTRUCTIONS for the PICTURE MODE.

Setting item VSM preset mode	1. CONT.	2. BRIGHT	3. SHARP	4. COLOUR	5. TINT
BRIGHT	+16	-2	+15	+5	0
STANDARD	+7	0	+2	0	0
SOFT	0	-2	-10	-2	0

SETTING VALUES OF VSM PRESET

VIDEO/CHROMA CIRCUIT ADJUSTMENT

The setting (adjustment) using the REMOTE CONTROL UNIT is made on the basis of the initial setting values. The setting values which adjust the screen to the optimum condition can be different from the initial setting values.

● marked * :Do not adjust

Colour system Setting item	Initial setting value			Colour system Setting item	Initial setting value		
	PAL	SECAM	NT SC		PAL	SECAM	NT SC
RGB BLK	—	—	—	8.TINT	—	—	000
2.WDR R	000	←	←	9.SHARP	* +007	←	←
3.WDR G	000	←	←	10.VCO ADJUSTMENT	Automatically optimized after adjustment		
4.WDR B	* -010	←	←	11.VID AGC	* 000	←	←
5.BRIGHT	000	←	←	12.SYC SLI	* +007	←	←
6.CONTRAST	000	←	←	13.A MOVIE	* +001	←	←
7.COLOUR	000	000	000				

Item	Measuring instrument	Test point	Adjustment part	Description
Adjustment of WHITE BALANCE (High-Light)	Signal generator Remote control unit		2.WDR R 3.WDR G	<ul style="list-style-type: none"> ● Set the PICTURE MODE to COOL. 1. Receive a black and white signal (colour off). 2. Select 2. V/C from the SERVICE MENU. 3. Modify 2. WDR R and 3.WDR G data to adjust the white balance (high light). 4. Press the MENU/OK key and memorize the set value. 5. Change the contrast and brightness with the remote control up & down from low-light to high-light and check that the tracking of the white balance is good.
Adjustment of SUB BRIGHT	Remote control unit		5.BRIGHT	<ul style="list-style-type: none"> 1. Receive any broadcast. 2. Select 2.V/C from the SERVICE MENU. 3. Select 5.BRIGHT with the function UP/DOWN key. 4. Set the initial setting value with the function LEFT/RIGHT key. 5. If the brightness is not the best with the initial setting value, make fine adjustment until you get the best brightness. 6. Press the MENU/OK key and memorize the set value.
Adjustment Of SUB CONTRAST.	Remote control unit		6.CONTRAST	<ul style="list-style-type: none"> 1. Receive any broadcast. 2. Select 2.V/C from the SERVICE MENU. 3. Select 6.CONTRAST with the function UP/DOWN key. 4. Set the initial setting value with the function LEFT/RIGHT key. 5. If the contrast is not the best with the initial setting value, make fine adjustment until you get the best contrast. 6. Press the MENU/OK key and memorize the set value.

Item	Measuring instrument	Test point	Adjustment part	Description
Adjustment of SUB COLOUR I	Remote control unit		7.COLOUR (PAL/SECAM/NTSC)	[Method of adjustment without measuring instrument]
			PAL COLOUR	(PAL COLOUR) 1. Receive PAL broadcast. 2. Select 2.V/C from the SERVICE MENU. 3. Select 7.COLOUR with the function UP/DOWN key. 4. Set the initial setting value for PAL COLOUR with the function LEFT/RIGHT key. 5. If the colour is not the best with the initial set value, make fine adjustment until you get the best colour. 6. Press the MENU/OK key and memorize the set value.
			SECAM COLOUR	(SECAM COLOUR) 1. Receive a SECAM broadcast. 2. Make fine adjustment of SECAM COLOUR in the same manner as for above.
NTSC COLOUR	(NTSC 3.58 COLOUR) 1. Input a NTSC 3.58MHz COMPOSITE VIDEO signal from the EXT terminal. 2. Make similar fine adjustment of NTSC 3.58 COLOUR in the same manner as for above. (NTSC 4.43 COLOUR) 1. Receive a NTSC 4.43MHz COMPOSITE VIDEO signal from the EXT terminal. 2. Make similar fine adjustment of 4.43 COLOUR in the same manner as for above.			

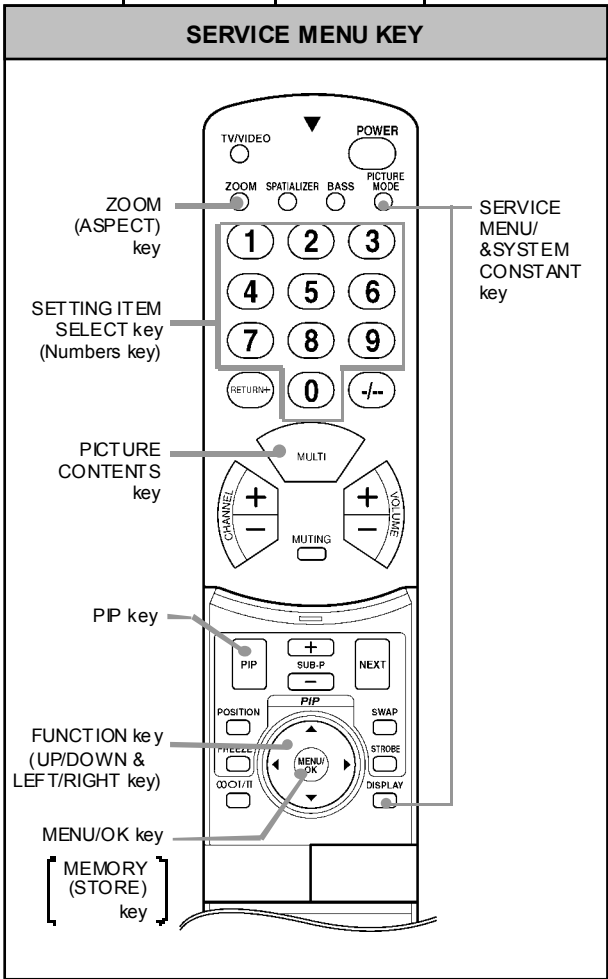

Item	Measuring instrument	Test point	Adjustment part	Description
Adjustment of SUB COLOUR II	Signal generator	TP-47B TP-E(↙) [CRT SOCKET PWB]	7.COLOUR (PAL/SECAM/NTSC)	[Method of adjustment using measuring instrument]
	Oscilloscope		PAL COLOUR	(PAL COLOUR) 1. Receive a PAL full field colour bar signal(75% white). 2. Select 2.V/C from the SERVICE MENU. 3. Select 7.COLOUR with the function UP/DOWN key. 4. Set the initial setting value of PAL COLOUR with the function LEFT/RIGHT key. 5. Connect the oscilloscope between TP-47B and TP-E 6. Adjust PAL COLOUR and bring the value of (A) in the illustration to +2V (voltage difference between white (w) and cyan (Cy)). 7. Press the MENU/OK key and memorize the setting value.
	Remote control unit		SECAM COLOUR	(SECAM COLOUR) 1. Receive a SECAM full field colour bar signal(75% white). 2. Select 2.V/C from the SERVICE MENU. 3. Select 7.COLOUR with the function UP/DOWN key. 4. Set the initial setting value of SECAM COLOUR with the function LEFT/RIGHT key. 5. Adjust SECAM COLOUR and bring the value of (A) of the illustration to +2V(W~Cy) . 6. Press the MENU/OK key and memorize the setting value.
	NTSC COLOUR		(NTSC 3.58 COLOUR) 1. Input a NTSC 3.58MHz COMPOSITE VIDEO signal (full field colour bar with 75% white) from the EXT terminal. 2. Select 2.V/C from the SERVICE MENU. 3. Select 7.COLOUR with the function UP/DOWN key. 4. Set the initial setting value of NTSC 3.58 COLOUR with the function LEFT/RIGHT key. 5. Adjust NTSC 3.58 COLOUR and bring the value of (A) of the illustration to +12V(W~Cy) . 6. Press the MENU/OK key and memorize the setting value. (NTSC 4.43 COLOUR) 1. Input a NTSC 4.43MHz COMPOSITE VIDEO signal (full field colour bar with 75% white) from the EXT terminal. 2. Select 2.V/C from the SERVICE MENU. 3. Select 7.COLOUR with the function UP/DOWN key. 4. Set the initial setting value of NTSC 4.43 COLOUR with the function LEFT/RIGHT key. 5. Adjust NTSC 4.43 COLOUR and bring the value of (A) of the illustration to +12V(W~Cy) . 6. Press the MENU/OK key and memorize the setting value.	

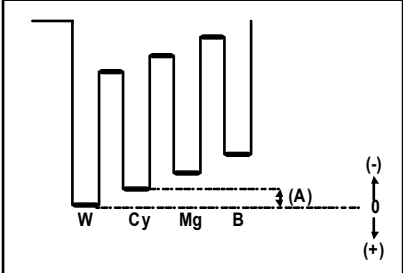

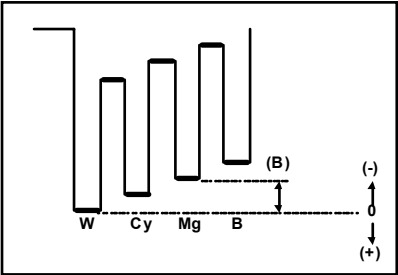
Item	Measuring instrument	Test point	Adjustment part	Description
Adjustment of SUB TINT	Remote control unit		8.TINT	[Method of adjustment without measuring instrument]
			NTSC 3.58 TINT	(NTSC 3.58 TINT) 1. Input a NTSC 3.58MHz COMPOSITE VIDEO signal (full field colour bar with 75% white) from the EXT terminal. 2. Select 2.V/C from the SERVICE MENU. 3. Select 8.TINT with the function UP/DOWN key. 4. Set the initial setting value of NTSC 3.58 TINT with the function LEFT/RIGHT key. 5. If you cannot get the best TINT with the initial setting value, make fine adjustment until you get the best TINT. 6. Press the MENU/OK key and memorize the set value.
			NTSC 4.43 TINT	(NTSC 4.43 TINT) 1. When NTSC 3.58 is set, NTSC 4.43 will be automatically set at the respective values.
Adjustment of SUB TINTII	Signal generator	TP-47B TP-E(↔) [CRT SOCKET PWB]	8.TINT	[Method of adjustment using measuring instrument]
	Oscilloscope		NTSC 3.58 TINT	(NTSC 3.58 TINT) 1. Input a NTSC 3.58MHz COMPOSITE VIDEO signal (full field colour bar with 75% white) from the EXT terminal. 2. Select 2.V/C from the SERVICE MENU. 3. Select 8.TINT with the function UP/DOWN key. 4. Set the initial setting value of NTSC 3.58 TINT with the function LEFT/RIGHT key. 5. Connect the oscilloscope between TP-47B and TP-E 6. Adjust NTSC 3.58 TINT to bring the value of (B) in the illustration to -13V (voltage difference between white (W) and magenta(Mg)). 7. Press the MENU/OK key and memorize the setting value
	Remote control unit		NTSC 4.43 TINT	(NTSC 4.43 TINT) 1. When NTSC 3.58 is set, NTSC 4.43 will be automatically set at the respective values.
				
Adjustment of VCO for colour decoder	Signal generator		10. VCO	[For main picture] 1. Input a PAL full field colour bar signal (75% white) from EXT terminal. 2. Select 2. V/C from the SERVICE MENU. 3. Then Select 10. VCO adjustment with the function UP/DOWN key. 4. Press the MENU/OK key. * When the MENU/OK key is pressed, VCO for colour decoder will be automatically set at the respective values. [For PIP] 5. Select 7.PIP from the SERVICE MENU. 6. Then select 1.PIP VCO ADJ with the function UP/DOWN key. * When the MENU/OK key is pressed, VCO for colour decoder will be automatically set at the respective values.
	Remote control unit			

DEF. CIRCUIT ADJUSTMENT

There are 3 aspect modes (①REGULAR, ②ZOOM & ③16 : 9) of the adjustment (1) 100Hz i mode, (2) 60Hz p and (3) 120Hz i mode depending upon the kind of signals (vertical frequency 100Hzi / 60Hzp / 120Hzi).

- When the 100Hz REGULAR mode has been established, the setting of other modes will be done automatically. However, if the picture quality has not been optimized, adjust each mode again, respectively.
- The adjustment using the remote control unit is made on the basis of the initial setting values.
- The setting values which adjust the screen to the optimum condition can be different from the initial setting values.

Setting item	Initial setting value					
	REGULAR		ZOOM		16 : 9	
	100Hz i	60Hz p	100Hz i	60Hz p	100Hz i	60Hz p
1. V- SHIFT	-3	+8	0	0	0	0
2. V-SIZE	+5	0	0	0	-15	0
3. H-CENT	-11	+3	0	0	0	0
4. H-SIZE	-11	-5	0	0	-3	+3
5. TRAPEZ	-16	+17	0	0	0	0
6. EW-PIN	-36	0	0	0	0	0
7. COR-PIN	0	0	0	0	0	0
8. COR-UP	0	0	0	0	0	0
9. COR-LO	0	0	0	0	0	0
10. ANGLE	0	0	0	0	0	0
11. BOW	0	0	0	0	0	0
12. V-S.CR	+5	0	0	0	0	0
13. V-LIN	-6	+4	0	0	0	0
14. V.BLK-UP	80	0	0	0	-82	-6

FIXED VALUE

: Do not move.

Item	Measuring instrument	Test point	Adjustment part	Description
<p>Adjustment of V-SHIFT</p>	<p>Signal generator Remote control unit</p>		<p>1.V- SHIFT</p>	<p>[REGULAR mode]</p> <ol style="list-style-type: none"> 1. Receive a circle pattern signal of vertical frequency 50Hz. 2. Select 4.DEF from the SERVICE MENU. 3. Select 1.V-SHIFT with the function UP/DOWN key. 4. Adjust V-SHIFT to make A = B. 5. Check the adjustment value above in other zoom mode. If it is a wrong adjustment, re-adjust in ZOOM mode and adjust by 1. V-SHIFT and 13.V-LIN. 6. Press the MENU/OK key and memorize the set value.
<p>Adjustment of V-SIZE</p>			<p>2.V-SIZE</p>	<ol style="list-style-type: none"> 7. Receive a cross-hatch signal. 8. Select 2.V-SIZE and set the initial setting value. 9. Adjust V-SIZE and make sure that the vertical screen size of the picture size is in the below table. 10. Press the MENU/OK key and memorize the set value. 11. Input a NTSC VIDEO signal (60Hz) from the EXT terminal, and make sure that the vertical screen size is in the below table. 12. Press the MENU/OK key and memorizethe set value.

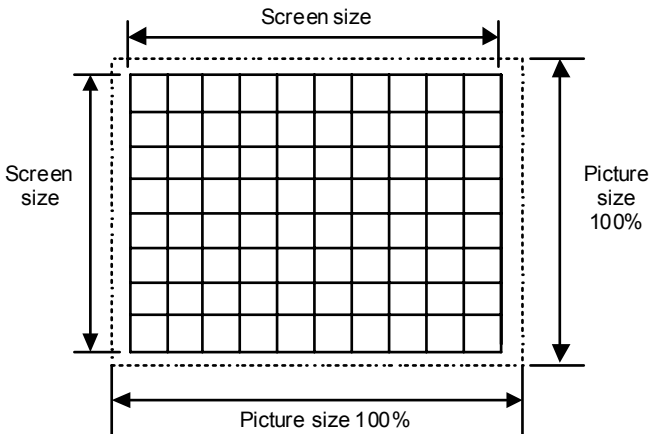
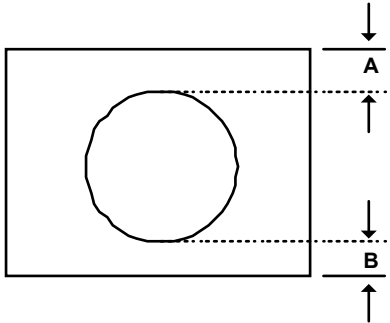

ASPECT SCREEN POSITION	ZOOM		
	REGULAR	ZOOM	16 : 9
TOP	93%	_____ (FIXED)	_____ (FIXED)
BOTTOM	93%	_____ (FIXED)	_____ (FIXED)

[SCREEN SIZE]

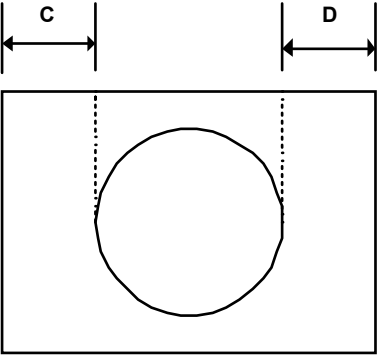
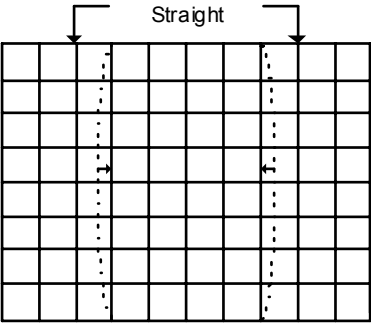
Item	Measuring instrument	Test point	Adjustment part	Description											
Adjustment of H. CENTER	Signal generator Remote control unit		3.H-CENT.	<p>13. Receive a circle pattern signal. 14. Select 3.H-CENT and set the initial setting value. 15. Adjust H-CENT to make C=D. 16. Press the MENU/OK key and memorize the set value.</p> 											
Adjustment Of H.SIZE			4.H-SIZE	<p>17. Receive a cross-hatch signal. 18. Select 4.H-SIZE and set the initial setting value. 19. Adjust H-SIZE and make sure that the horizontal screen size of the picture size is in the below table. 20. Press the MENU/OK key and memorize the set value. 21. Input a NTSC VIDEO signal (60Hz) from the EXT terminal, and make sure that the horizontal screen size is in the below table. 22. Press the MENU/OK key and memorize the set value.</p> <table border="1" data-bbox="740 1225 1469 1391"> <thead> <tr> <th data-bbox="740 1225 922 1279" rowspan="2">ASPECT MODE ADJ. ITEM</th> <th colspan="3" data-bbox="922 1225 1469 1279">ZOOM</th> </tr> <tr> <th data-bbox="922 1279 1104 1332">REGULAR</th> <th data-bbox="1104 1279 1286 1332">ZOOM</th> <th data-bbox="1286 1279 1469 1332">16 : 9</th> </tr> </thead> <tbody> <tr> <td data-bbox="740 1332 922 1391">H-SIZE</td> <td data-bbox="922 1332 1104 1391">92%</td> <td data-bbox="1104 1332 1286 1391">_____ (FIXED)</td> <td data-bbox="1286 1332 1469 1391">_____ (FIXED)</td> </tr> </tbody> </table>	ASPECT MODE ADJ. ITEM	ZOOM			REGULAR	ZOOM	16 : 9	H-SIZE	92%	_____ (FIXED)	_____ (FIXED)
ASPECT MODE ADJ. ITEM	ZOOM														
	REGULAR	ZOOM	16 : 9												
H-SIZE	92%	_____ (FIXED)	_____ (FIXED)												
Adjustment of EW-PIN			6.EW-PIN	<p>23. Select 6.EW-PIN and set the initial setting value 24. Adjust EW-PIN and make the 2nd.vertical lines at the left and right edges of the screen straight. Also make sure that the 3rd vertical lines are straight. 25. Press the MENU/OK key and memorize the set value.</p> 											

Item	Measuring instrument	Test point	Adjustment part	Description
Adjustment of TRAPEZ	Signal generator Remote control unit		5.TRAPEZ	<p>26. Receive a cross-hatch signal.</p> <p>27. Select 5.TRAPEZ with the function UP/DOWN key.</p> <p>28. Set the initial setting value of TRAPEZ with the function LEFT/RIGHT key.</p> <p>29. Adjust TRAPEZ and bring the VERTICAL lines at the right and left edges of the screen parallel .</p> <p>30. Press the MENU/OK key and memorize the set value.</p>
Adjustment of CORNER UP/ LOW	Signal generator Remote control unit		7.COR-PIN 8.COR-UP 9.COR-LO	<p>31. Select 9.COR-LO with the FUNCTION UP / DOWN key.</p> <p>32. Set the initial setting value of 9.COR-LO with the function LEFT/RIGHT key.</p> <p>33. Adjust COR-LO, and bring the straight line at the low comer.</p> <p>34. Select 8.COR-UP with the function UP / DOWN key.</p> <p>35. Set the initial setting value of 8.COR-UP with the function LEFT/RIGHT key.</p> <p>36. Adjust COR-UP, and bring the straight line at the upper corner.</p> <p>37. If the extreme upper & lower corners and a little pin or barrel, chose 7.COR-PIN and adjust. And adjust to get the straight.</p> <p>38. Press the MENU/OK key and store the set value.</p>
Adjustment of ANGLE	Signal generator Remote control unit		10.ANGLE	<p>● In case where there is a parallelogrammical distortion of images on the screen. (Fig. A)</p> <p>39. Select 10.ANGLE with the FUNCTION UP / DOWN key.</p> <p>40. Adjust ANGLE, and bring the VERTICAL lines straight.</p> <p>41. Press the MENU key and memorize the set value.</p>

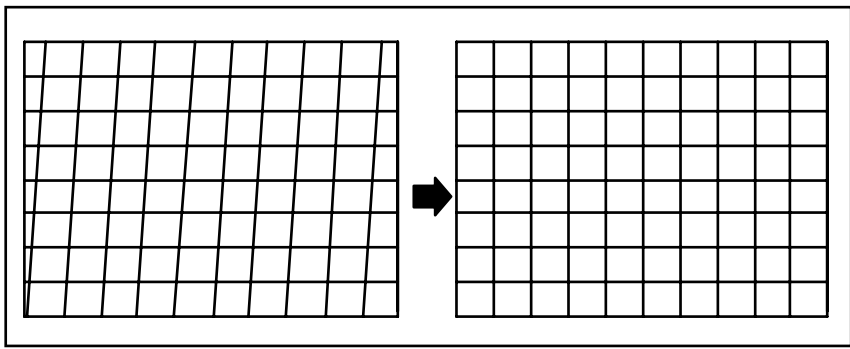
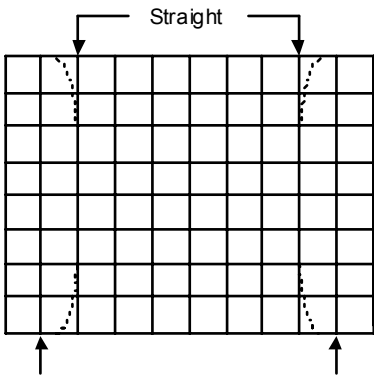
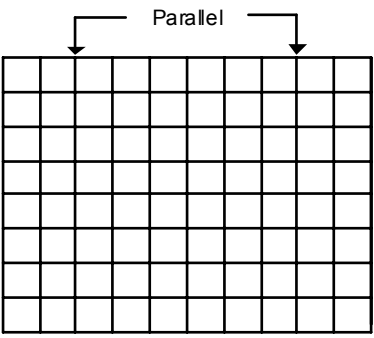

Fig. A

Item	Measuring instrument	Test point	Adjustment part	Description
Adjustment of BOW	Signal generator Remote control unit		11.BOW	<ul style="list-style-type: none"> In case where there is a bow-shaped distortion of images on the screen. (Fig.B) <p>42. Select 11.BOW with the function UP/DOWN key. 43. Adjust BOW, and bring the VERTICAL lines straight. 44. Press the MENU/OK key and memorize the set value.</p> <div data-bbox="284 566 1265 904" style="text-align: center;"> </div> <p style="text-align: center;">Fig. B</p>
Adjustment of V-S.CR & V.LINE			12.V-S.CR 13.V.LIN.	<ul style="list-style-type: none"> When the vertical linearity has been deteriorated remarkably, perform the following steps. <p>45. Receive a cross-hatch signal. 46. Select 13. V.LIN with the function UP / DOWN key. 47. Set the initial setting value of 13. V.LIN with the function LEFT/RIGHT key. 48. Select 12. V-S.CR. with the function UP / DOWN key. 49. Set the initial setting value of 12. V-S.CR. with the function LEFT/RIGHT key. 50. Adjust 13. V.LIN and 12. V-S.CR. so that the spaces of each line on TOP, CENTER, and BOTTOM become uniform.</p> <p>NOTE : Do not adjust "ZOOM" & "16 : 9" mode.</p> <div data-bbox="284 1227 791 1532" style="text-align: center;"> </div>
				<p>* At first the adjustment in 50Hz REGULAR mode should be done, then the data for the other ZOOM mode is corrected in the respective value at the same time. And confirm the deflection adjustment initial setting value in 60Hz (NTSC EXT mode) REGULAR mode.</p> <p>If the adjustment in 50Hz REGULAR mode has been done and stored, the data for the other ZOOM modes is corrected in the same value at the same time.</p> <p>* Only the data for the other ZOOM mode in 60Hz is corrected for it self.</p>

AUDIO CIRCUIT ADJUSTMENT

- Do not touch **3. AUDIO** adjustment of the SERVICE MENU as it requires no adjustment.
If values had changed for the some reason, set the initial values in the following table.

3. AUDIO(Do not adjust)

Setting item	Variable range	fixed value
1. ERR LIMIT	00H~FFH	10H
2. A2 ID THR	00H~FFH	14H
3. QUASI	00H~FFH	_____

PURITY, CONVERGENCE ADJUSTMENT

PURITY ADJUSTMENT

1. Demagnetize CRT with the demagnetizer.
2. Loosen the retainer screw of the deflection yoke.
3. Remove the wedges.
4. Input a green raster signal from the signal generator, and turn the screen to green raster.
5. Move the deflection yoke backward.
6. Bring the long lug of the purity magnets on the short lug and position them horizontally. (Fig.2)
7. Adjust the gap between two lugs so that the GREEN RASTER will come into the center of the screen. (Fig.3)
8. Move the deflection yoke forward, and fix the position of the deflection yoke so that the whole screen will become green.
9. Insert the wedge to the top side of the deflection yoke so that it will not move.
10. Input a cross hatch signal.
11. Verify that the screen is horizontal.
12. Input red and blue raster signals, and make sure that purity is properly adjusted.

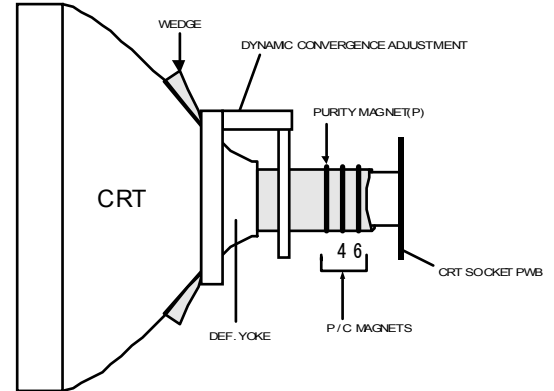

P/C MAGNETS

- P : PURITY MAGNET
- 4 : 4 POLES (convergence magnets)
- 6 : 6 POLES (convergence magnets)

Fig.1

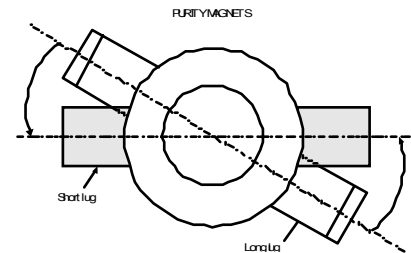

Bring the long lug over the short lug and position them horizontally.

Fig.2

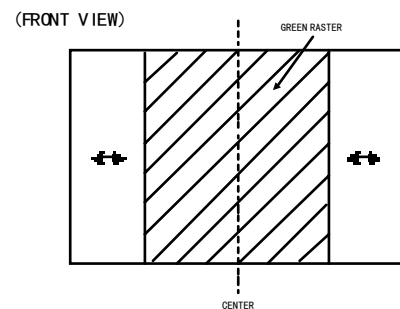

Fig.3

STATIC CONVERGENCE ADJUSTMENT

1. Input a cross hatch signal.
 2. Using 4-pole convergence magnets, overlap the red and blue lines in the center of the screen (Fig.1) and turn them to magenta (red/blue).
 3. Using 6-pole convergence magnets, overlap the magenta (red/blue) and green lines in the center of the screen and turn them to white.
 4. Repeat 2 and 3 above, and make best convergence.
- After adjustment, fix the wedge at the original position.
Fasten the retainer screw of the deflection yoke.
Fix the 6 magnets with glue.

DYNAMIC (periphery) CONVERGENCE ADJUSTMENT

After adjusting purity & static convergence.

1. Move the deflection yoke up and down to adjust the pin cushion distortion in the screen top and bottom. (See Fig. 2)
2. Move the deflection yoke left to right to overlap the lines in the periphery, and match the Y_v(VR1). (As shown in Fig. 4)
3. Using the VR1 on the deflection yoke, match the Y_H (CROSS). (See Fig. 3 and 6)
4. Using the VR2 on the deflection yoke, match the Y_H (BOW). (See Fig. 3 and 6)
5. Repeat the steps 1 and 4 and obtain an optimum convergence.
6. Differential(X_v) coil ADJUSTMENT.
In case where the horizontal lines of red and blue around the center of both sides of the picture as shown in Fig. 5, adjust the X_v difference by using the differential coil(X_v coil) on the top of the deflection yoke (Fig. 6) so as to minimize the X_v difference.

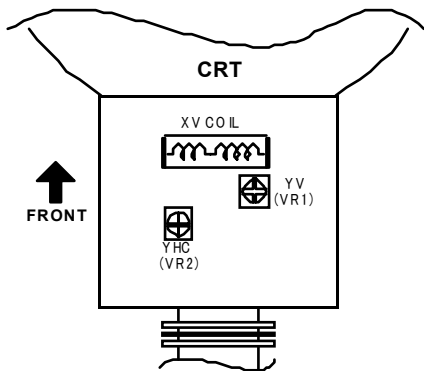

Fig.6

(FRONT VIEW)

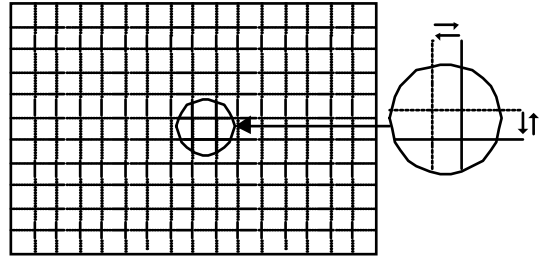

Fig. 1

(FRONT VIEW)

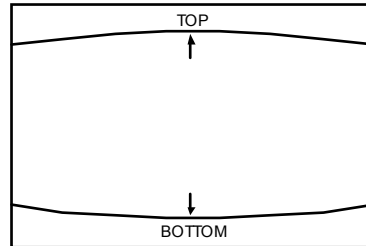

Fig. 2

(FRONT VIEW)

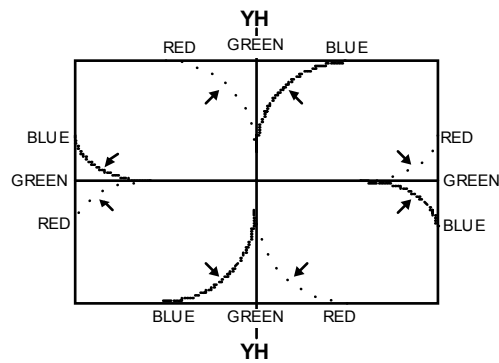

Fig. 3

(FRONT VIEW)

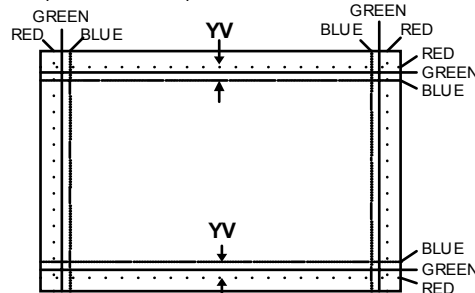

Fig. 4

(FRONT VIEW)

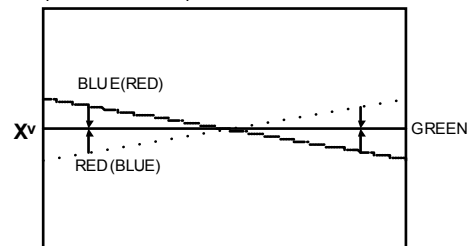

Fig. 5

REPLACEMENT OF CHIP COMPONENT

■ CAUTIONS

1. Avoid heating for more than 3 seconds.
2. Do not rub the electrodes and the resist parts of the pattern.
3. When removing a chip part, melt the solder adequately.
4. Do not reuse a chip part after removing it.

■ SOLDERING IRON

1. Use a high insulation soldering iron with a thin pointed end of it.
2. A 30w soldering iron is recommended for easily removing parts.

■ REPLACEMENT STEPS

1. How to remove Chip parts

◆ Resistors, capacitors, etc

- (1) As shown in the figure, push the part with tweezers and alternately melt the solder at each end.

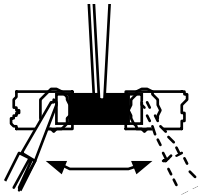

- (2) Shift with tweezers and remove the chip part.

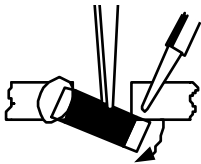

◆ Transistors, diodes, variable resistors, etc

- (1) Apply extra solder to each lead.

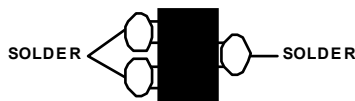

- (2) As shown in the figure, push the part with tweezers and alternately melt the solder at each lead. Shift and remove the chip part.

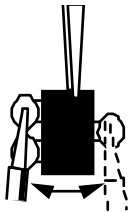

Note : After removing the part, remove remaining solder from the pattern.

2. How to install Chip parts

◆ Resistors, capacitors, etc

- (1) Apply solder to the pattern as indicated in the figure.

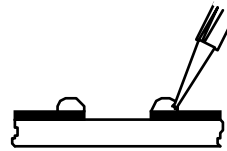

- (2) Grasp the chip part with tweezers and place it on the solder. Then heat and melt the solder at both ends of the chip part.

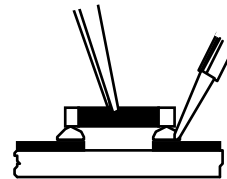

◆ Transistors, diodes, variable resistors, etc

- (1) Apply solder to the pattern as indicated in the figure.
- (2) Grasp the chip part with tweezers and place it on the solder.
- (3) First solder lead **A** as indicated in the figure.

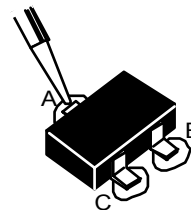

- (4) Then solder leads **B** and **C**.

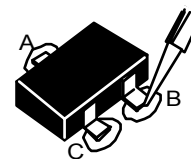

.. HV-34LPZ